

HARMONY

Project Statement

My project employs wind chimes to animate the sound of the wind , building a bridge for interaction and communication. This allows those within the space to feel the harmony between humans and nature.

**“ The world is born with me, and
everything is one with me ”**

-- ZhuangZi

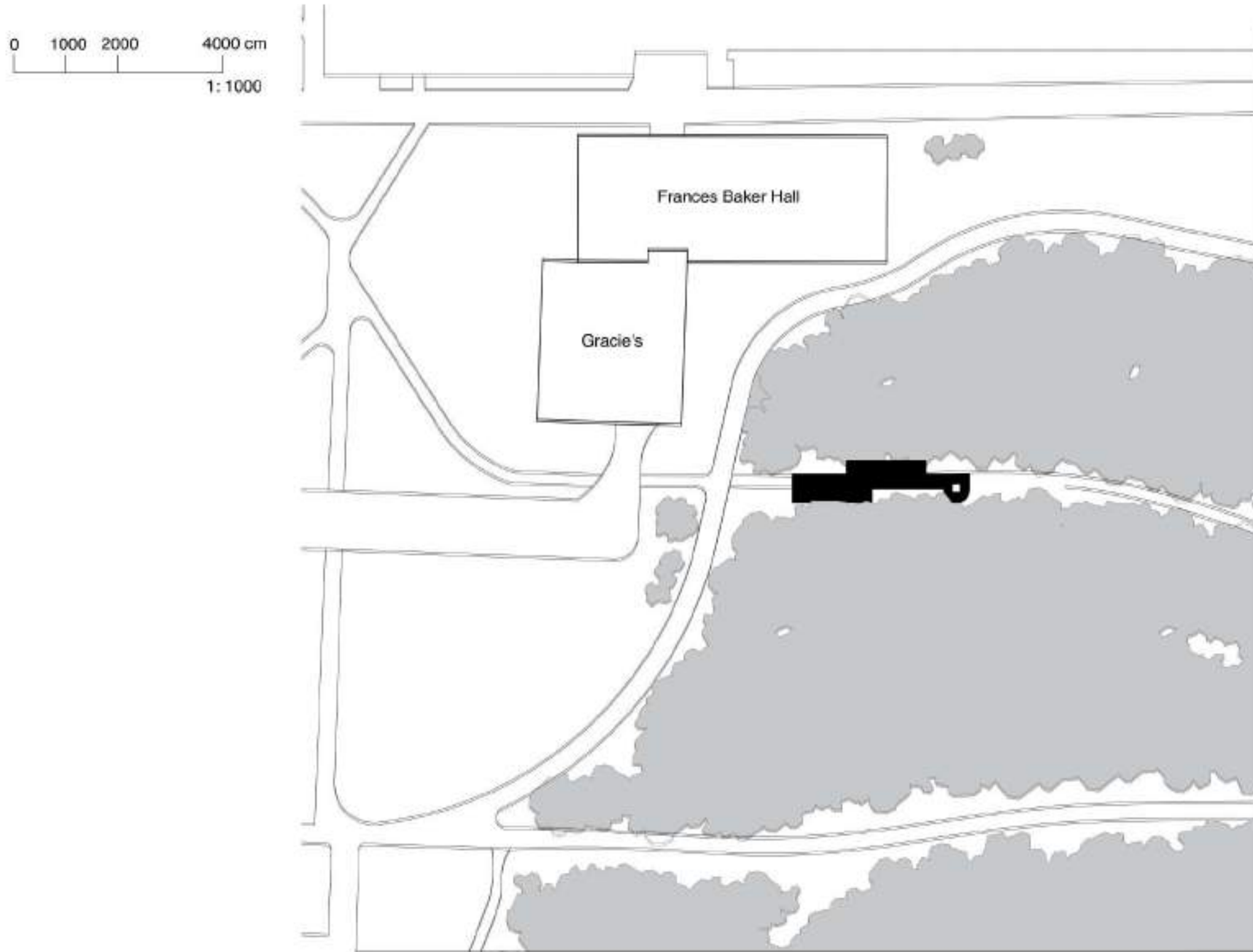

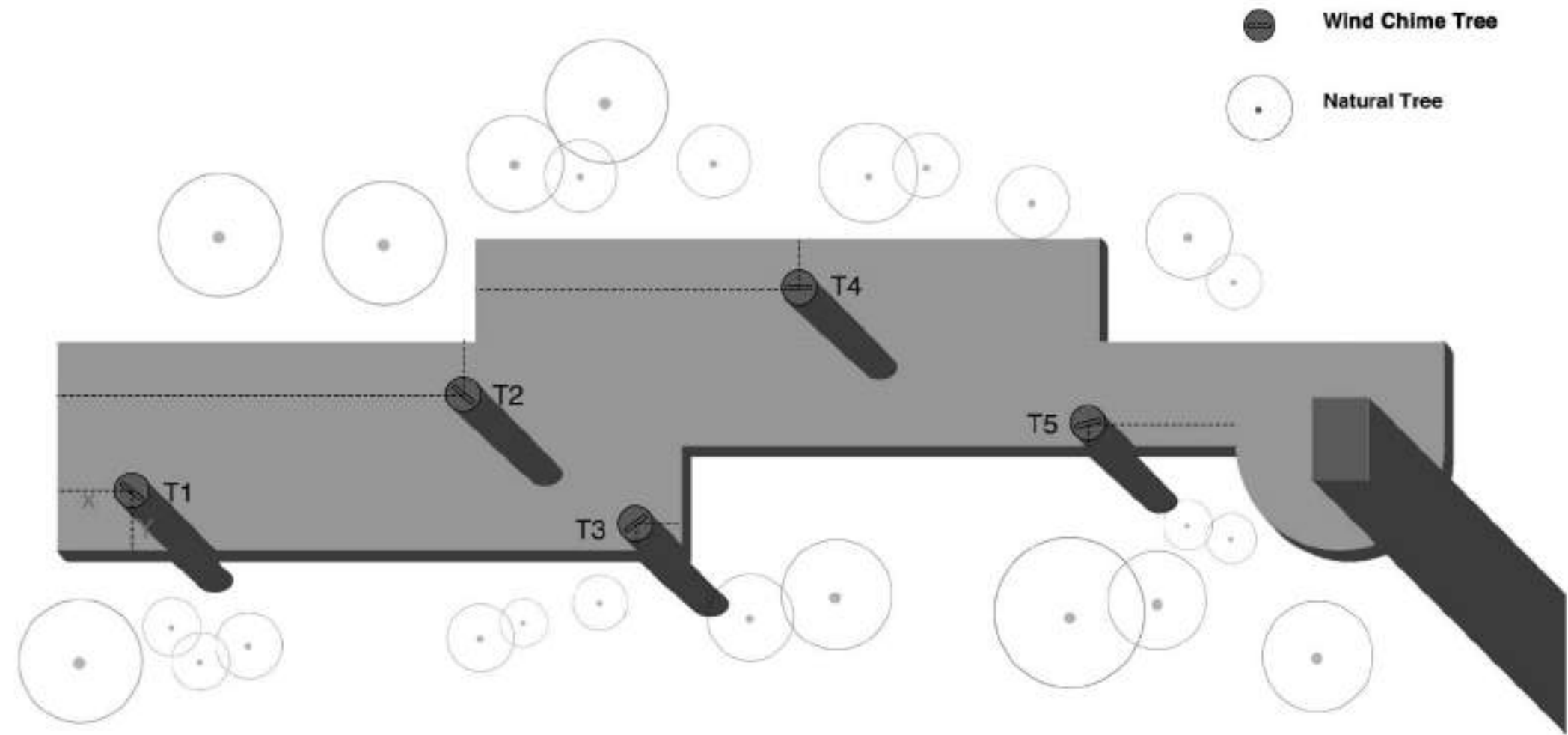
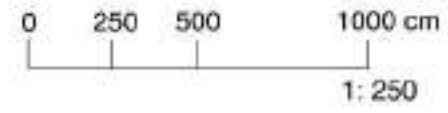

- Wind Chime Tree
- Natural Tree

TN (X, Y)
T1 (135, 135)
T2 (820, 15)
T3 (75, 50)
T4 (685, 105)
T5 (600, 45)

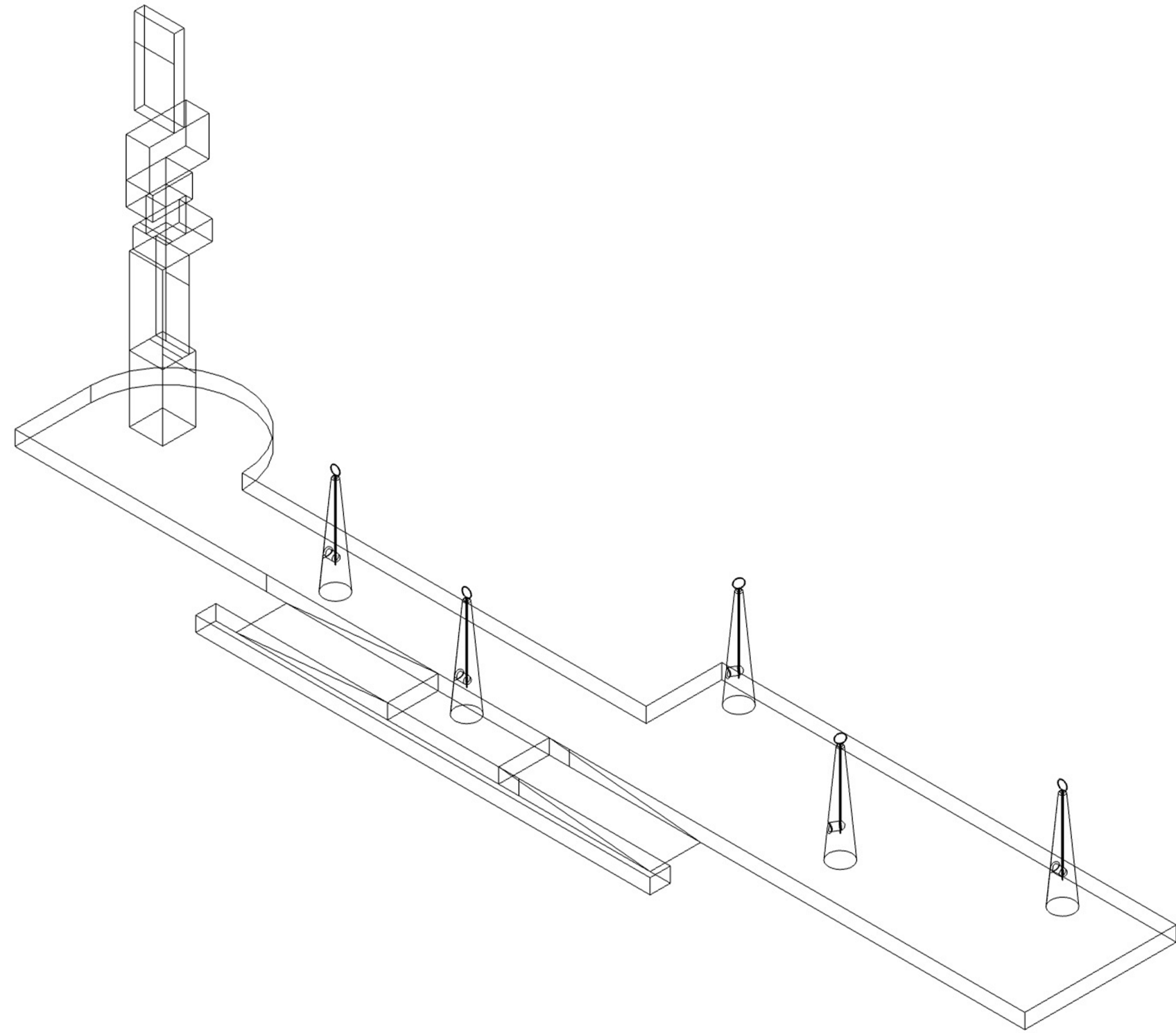

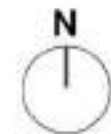
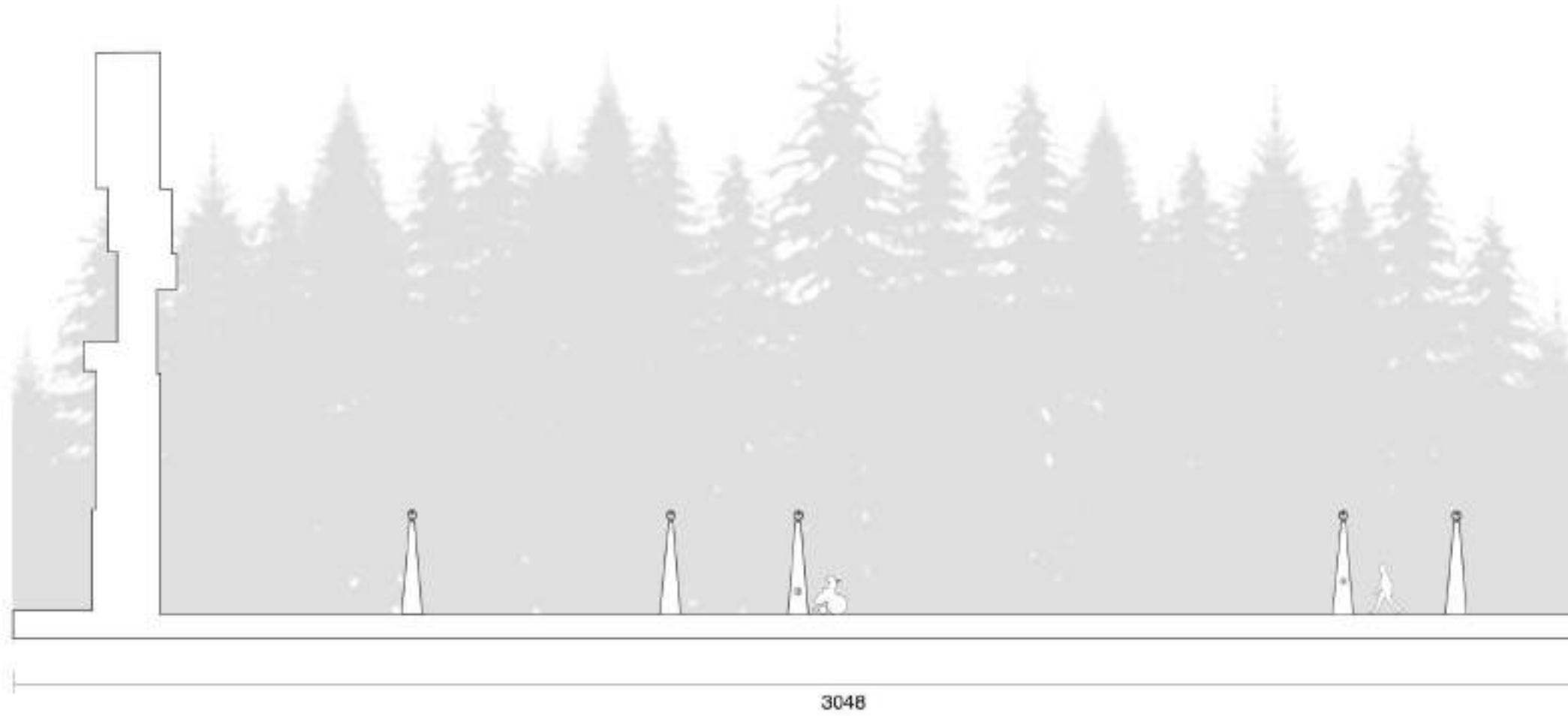
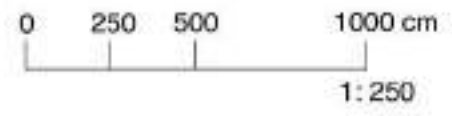

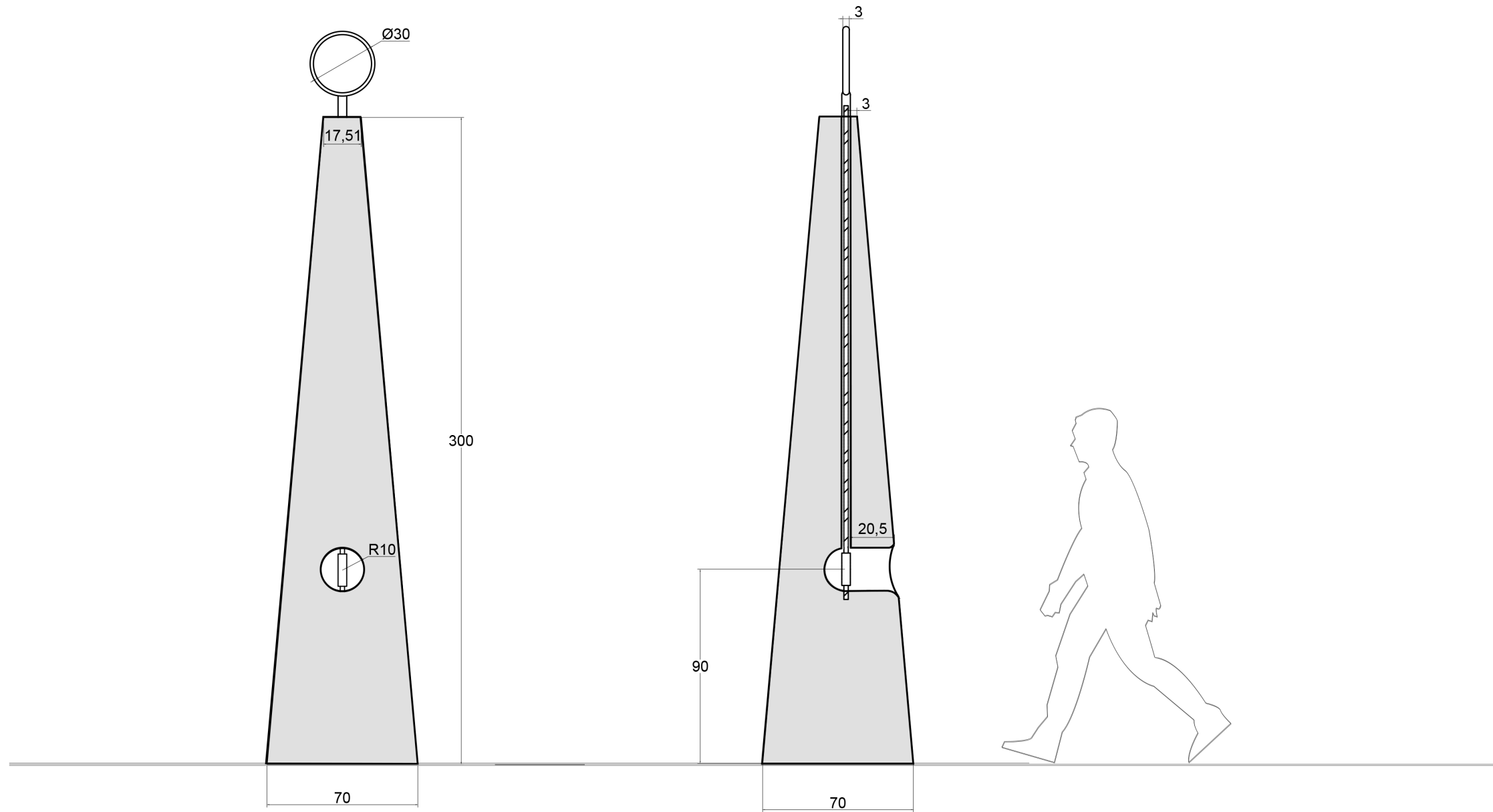
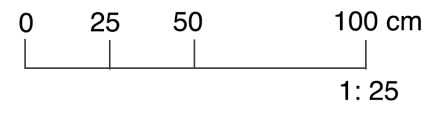

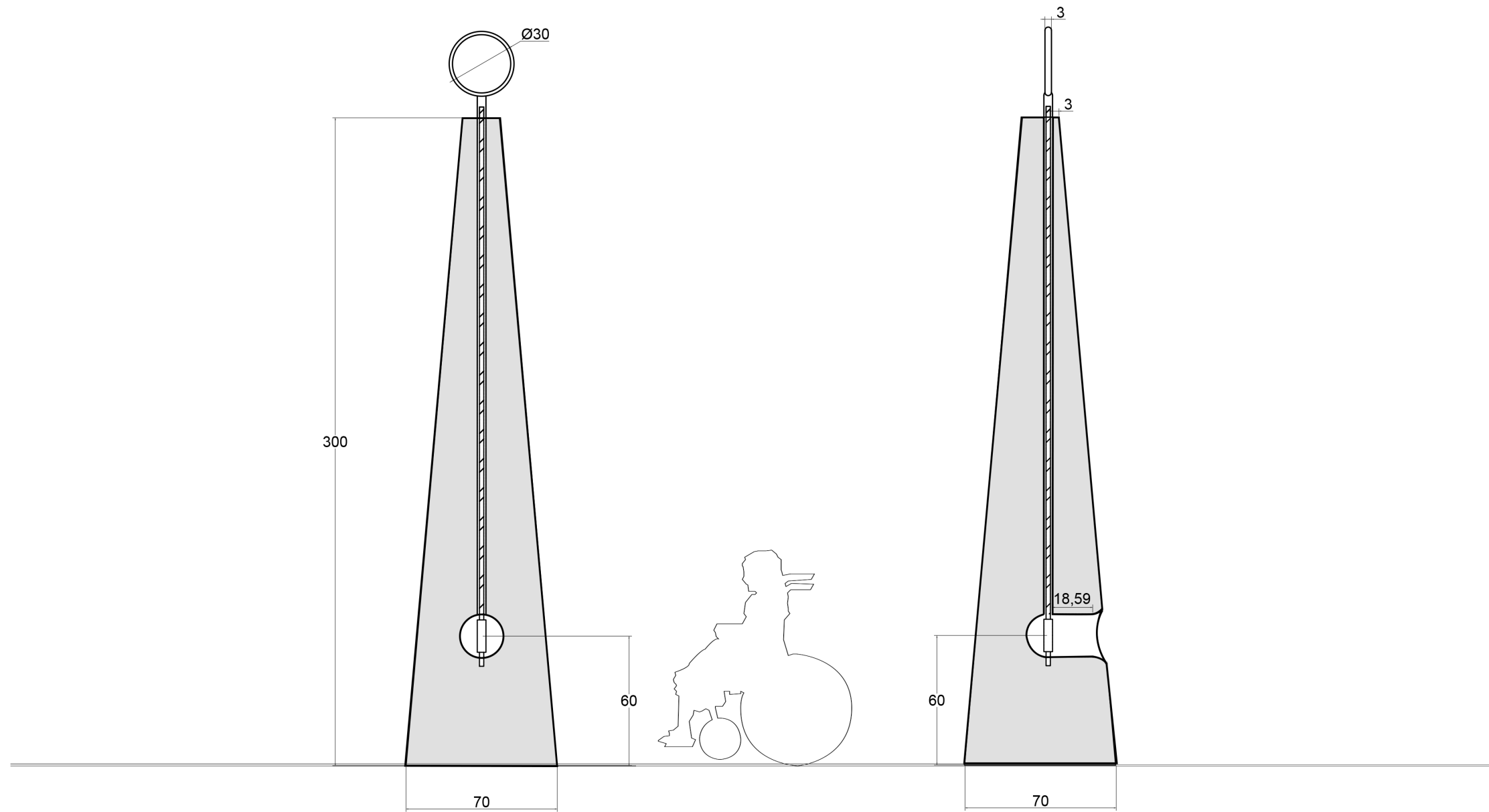
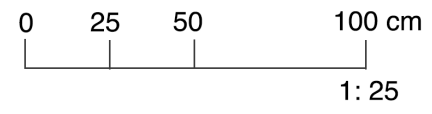

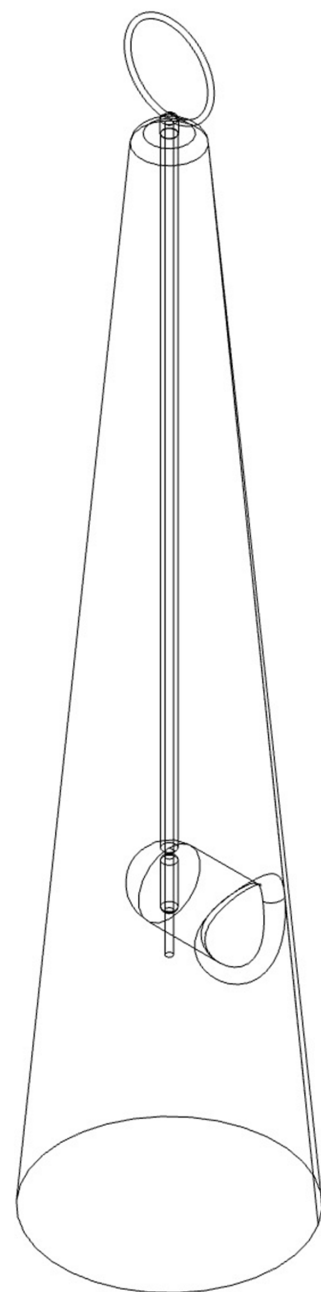

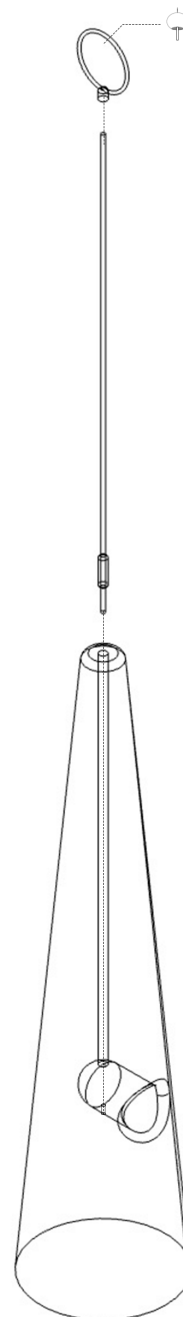

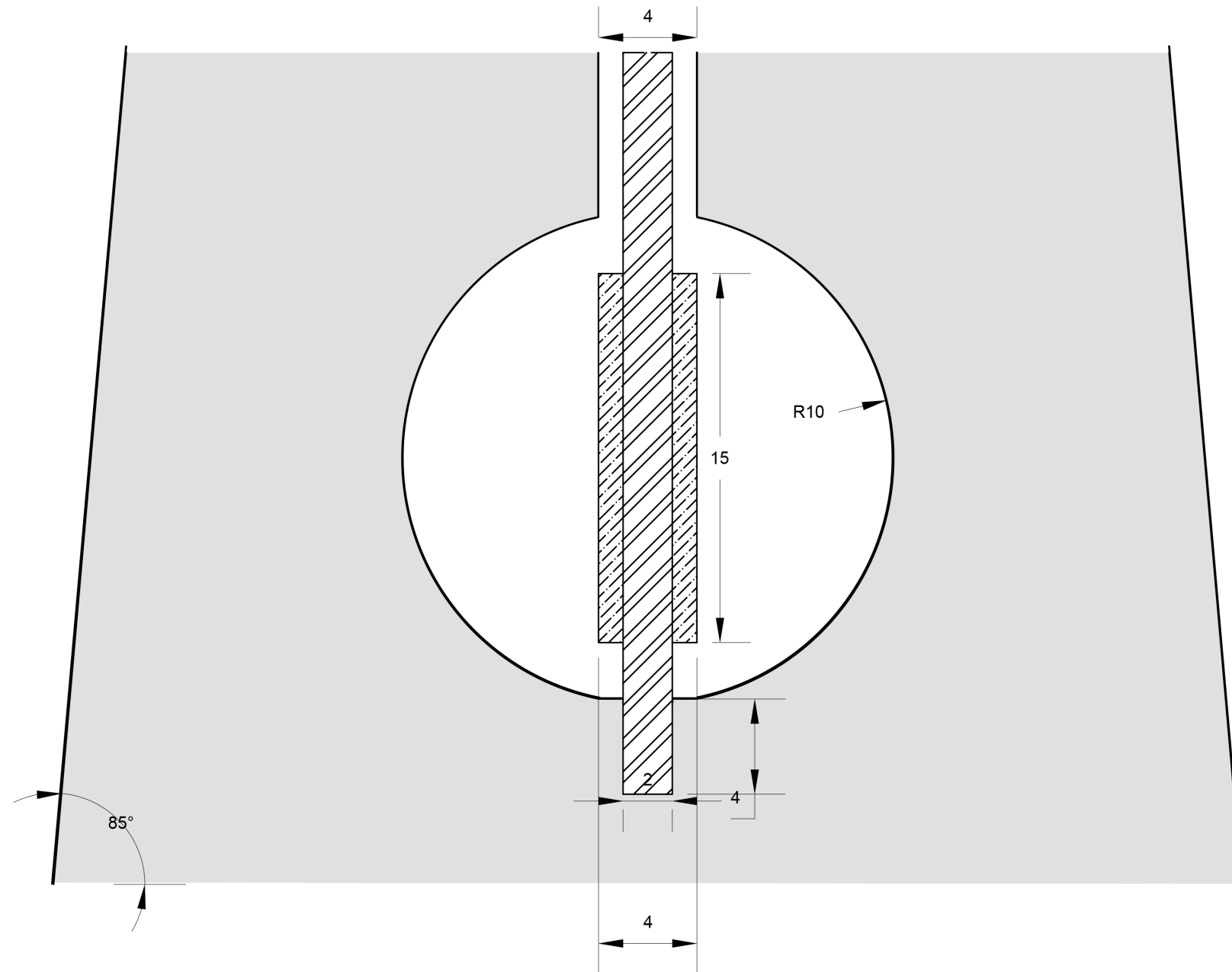
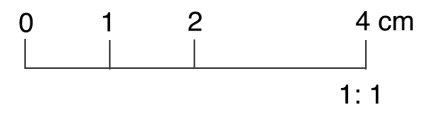

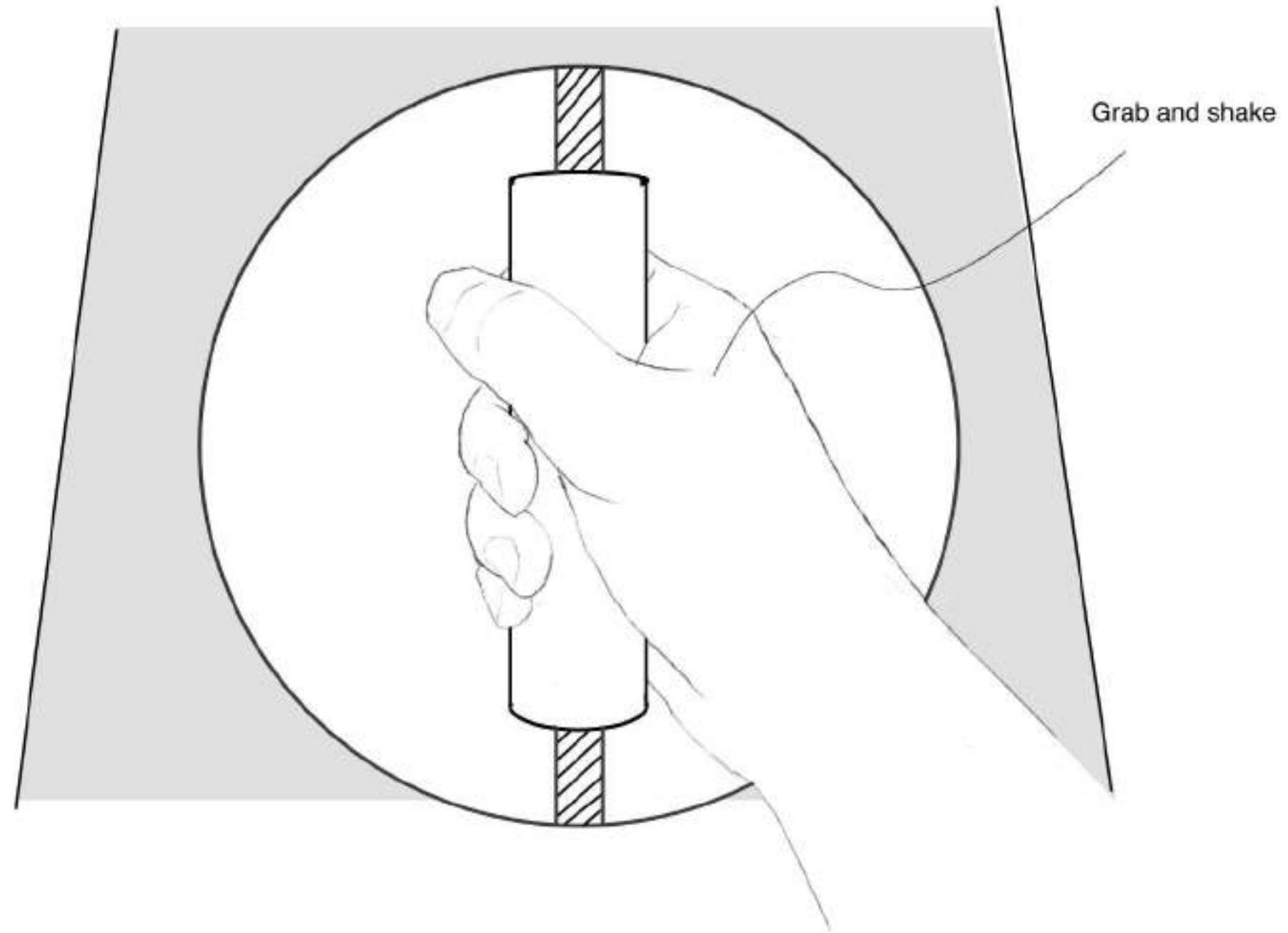

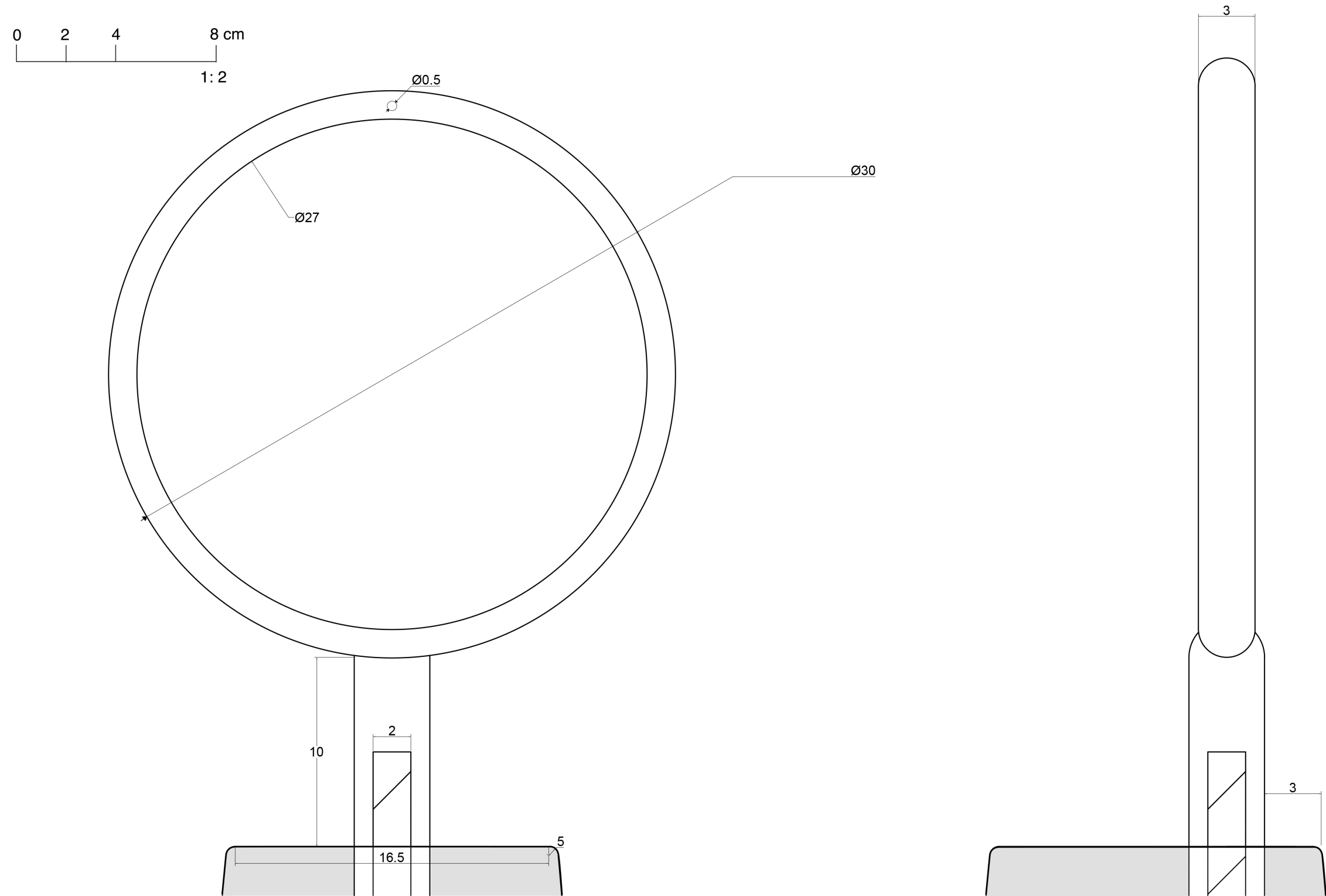

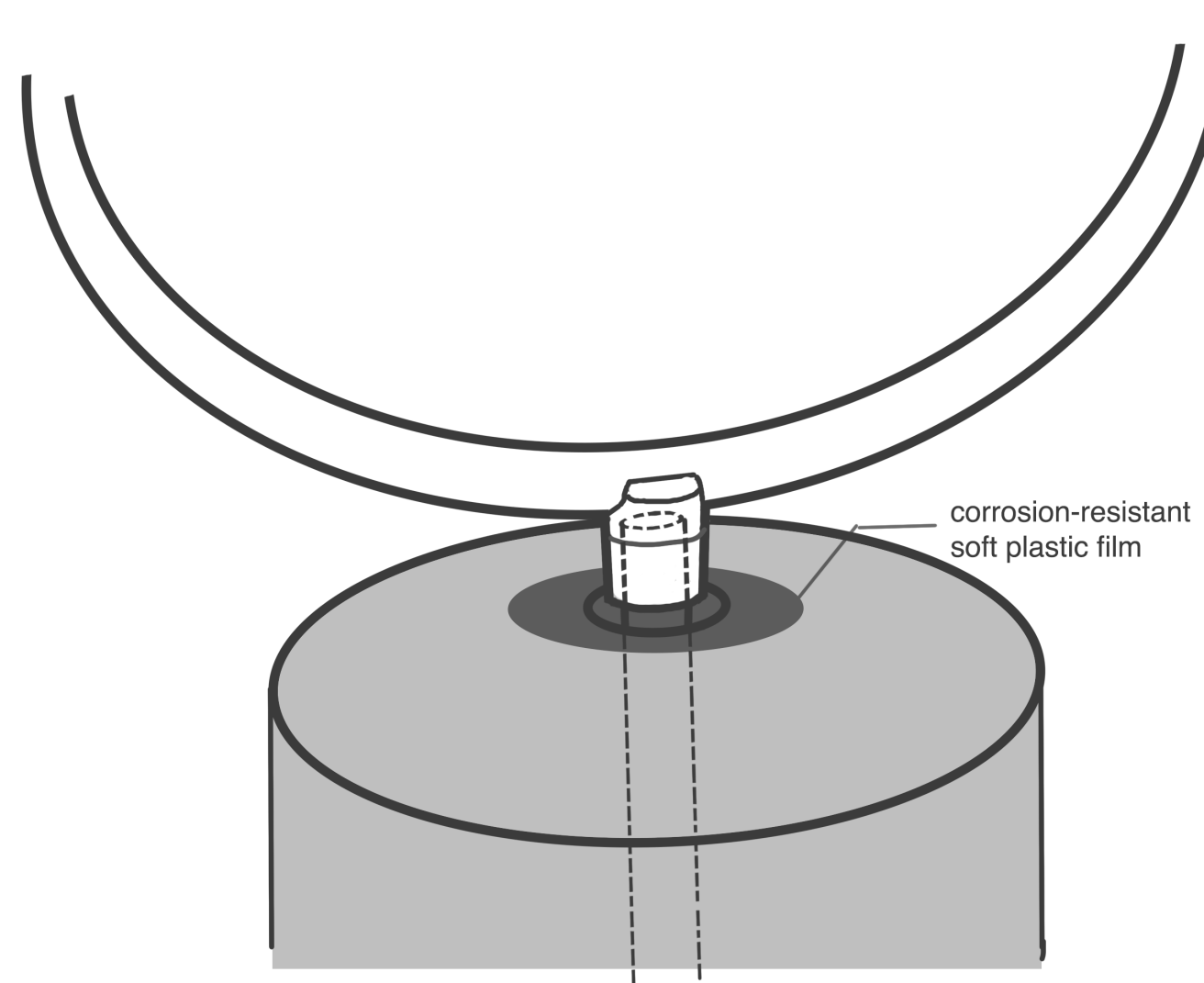

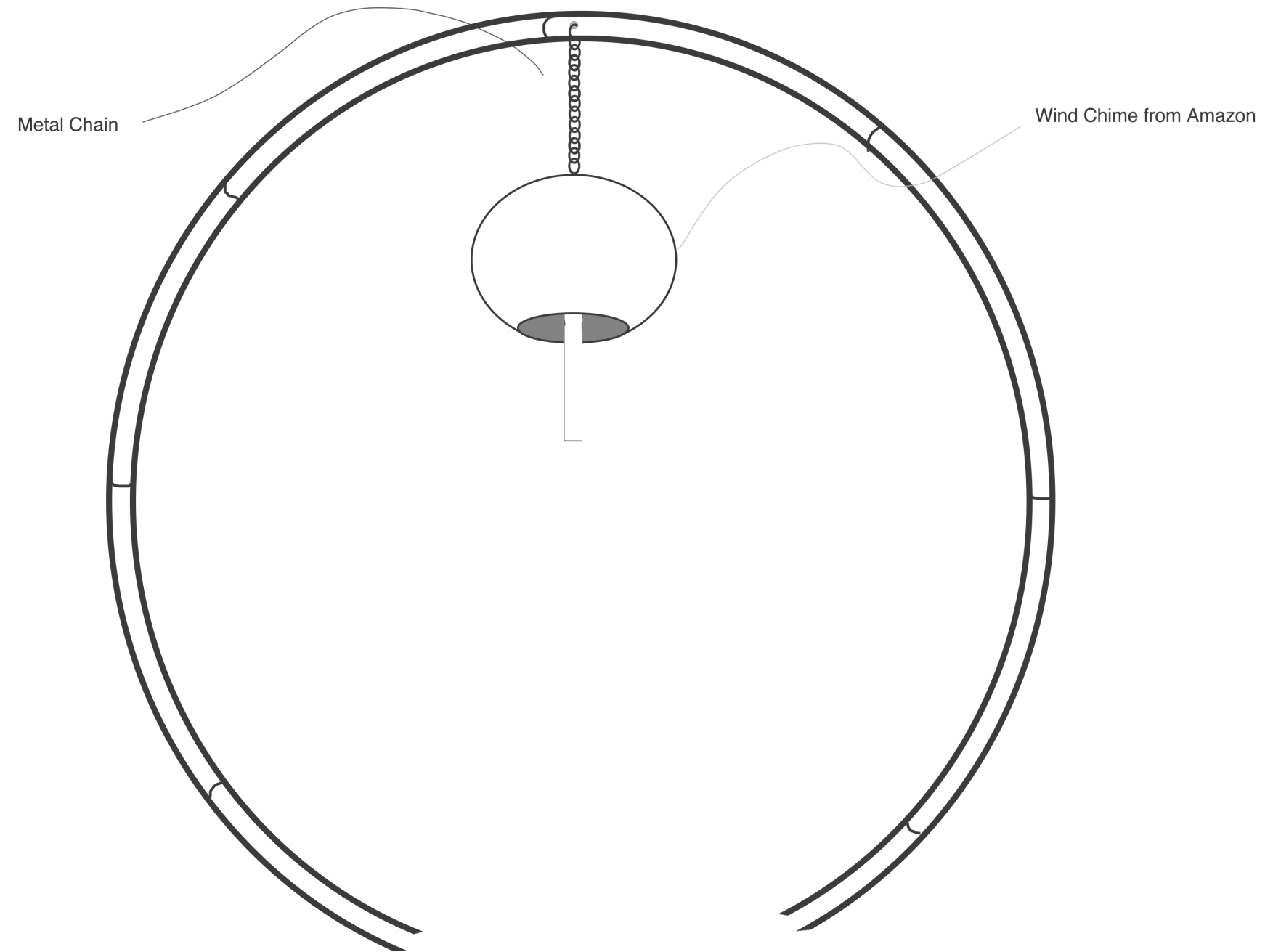

All Parts and materials

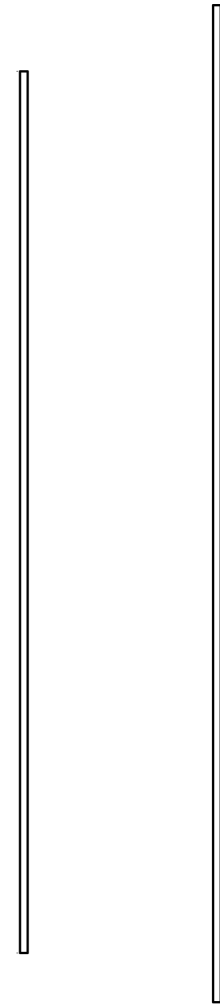

Fiberglass rod

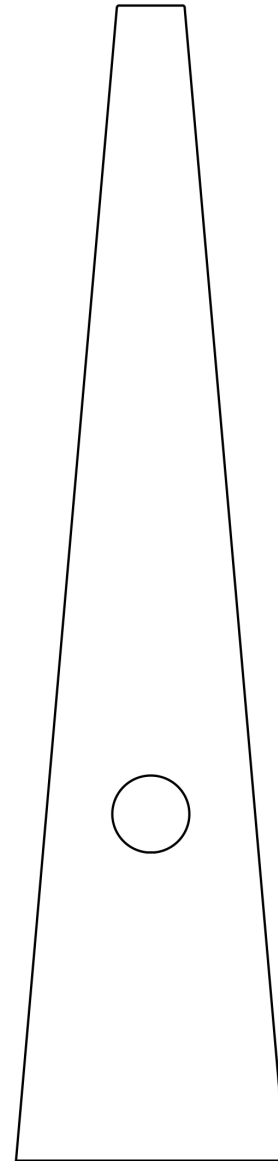

Concrete

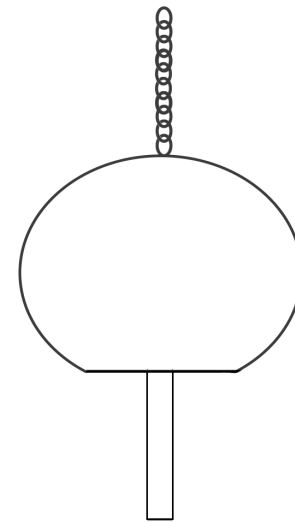

Metal Windchime

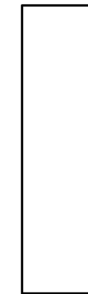

Rubber handle

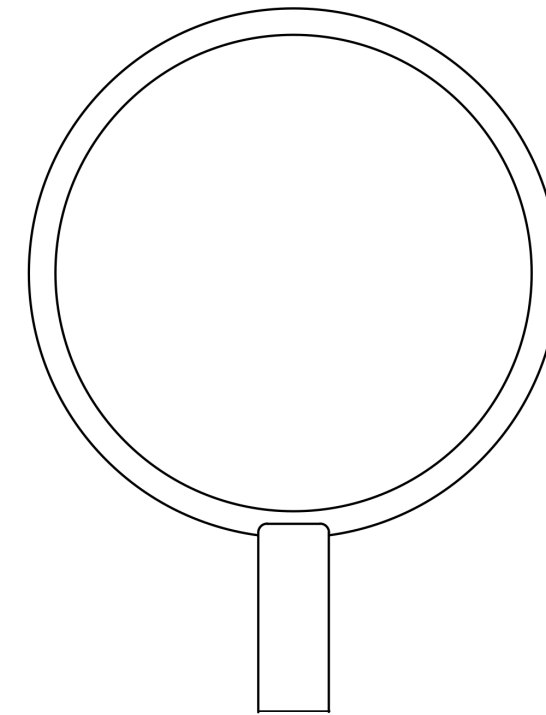

High Density Polyethylene (HDPE)

Material expert



Charles Carson
Senior Lecturer
College of Art and Design

✉ cgcaaa@rit.edu
☎ 585-475-4706

Consultant



Josh Owen
Vignelli Center Director
College of Art and Design

✉ jkofaa@rit.edu
☎ 585-475-2658

Consultant



Reza Aliabadi
Founder of Atelier RZLBD
Vignelli Center Designer in
Residence

✉ info@rzlbd.com

Consultant



Patricia Moore
Industrial Designer

Consultant



Eric Avar
Sneaker Designer
Nike's vice president of
design innovation

Wind Chime Suppliers



