

RIT | Vignelli Center for
Design Studies

**CORNING
MUSEUM
OF GLASS**

2024

**Sunday, June 2-
Saturday, June 8**

Summer Design Workshop

In Partnership with The Corning Museum of Glass

Invitation

An invitation for up to 10 students and designers from the global art community to participate in a week-long workshop that is divided between the Vignelli Center for Design Studies at RIT in Rochester, New York and The Corning Museum of Glass in Corning, New York.

Inspired by the Vignelli Archives, participants will develop a project of their own design that they will explore under the supervision of Vignelli Center staff and through the facilitation of master craft glass blowers from The Corning Museum of Glass. Participants will enjoy a week experiencing the food and culture of the Finger Lakes Region in late spring while connecting with unique design resources found in Upstate New York. Each participant will leave with a 3D printed prototype from the RIT Fab Lab and their final glass project fabricated at The Corning Museum of Glass.

Over the course of the workshop, designers will be introduced to the extensive archives of the Vignelli Center that catalogs decades of process and innovation from an incredibly influential designer duo—Lella and Massimo Vignelli, among many other renowned designers. With guidance by Vignelli Center staff and a Project Leader, participating artists will be encouraged to reflect on the Vignellis' design thinking and consider for themselves how to engage with historic visionaries while finding their own voice in the iconic and challenging art form that is glasswork.

Workshop Information Admissions Process

Up to 10 participants will be invited based on a portfolio review completed by Josh Owen

Portfolio Guidelines

Examples of work should show evidence of strong understanding of design, history, and an interest in modernism

Minimum of 5 projects

Submissions

Due by or before 15 January 2024

Acceptance decisions will be made 15 March 2024

Please submit your portfolio in the form of a multi-page PDF or a link to your online portfolio

Send to josh.owen@rit.edu

Selected participants will receive an invitation

Cost

\$2,500

Includes materials, daily lunch, kickoff and farewell dinner

Participants will be expected to provide their own transportation to and from Rochester, NY, as well as lodging in Rochester and Corning

Confirmation Letter

If selected, you will receive a confirmation letter

This letter will include an invoice, further details and an in-depth schedule

The Vignelli Center for Design Studies at RIT

In 2010, renowned designers Lella and Massimo Vignelli donated their career archive to RIT, where the collection is the major resource at the Vignelli Center for Design Studies. This world-class facility is a design museum accessible to all students, faculty, practitioners, and scholars. The Center, a prominent legacy to the Vignellis and influential Modernists, sustains the Vignelli goal of “better design for a better world.” It is an international hub for education, preservation, and advocacy whose distinctive archival resources work in tandem with relevant programming to provide a dynamic learning environment on the RIT campus.

The archive collections housed in the Vignelli Center for Design Studies demonstrate and inspire solutions to key and ubiquitous societal needs. By providing opportunities for varied programming for diverse audiences, the Center extends the value of design for positive impact on the future.



Vignelli Center Resources

Benetton Gallery

Located on the ground level and accessed through the University Gallery, this selection of Vignelli-designed products, graphics and packaging was curated by the Vignellis themselves. This grouping shows the substantial range and impact of their work.



The Archives

Lella and Massimo Vignelli worked across all fields of design and their archives include examples of industrial and product design, graphics and publication design, corporate identity programs, architectural graphics, exhibitions, interiors, and furniture design. These collections also feature unique materials related to the Vignellis' design process, such as sketches, prototypes, models, technical plans, correspondence, contracts, mechanicals, photographs, material samples, videos, and digital files.



Corning Museum of Glass

Established in 1951 by Corning Glass Works (now Corning Incorporated) as a gift to the nation for the company's 100th anniversary, The Corning Museum of Glass is a not-for-profit museum dedicated to exploring a single material: glass. Annually welcoming just under half a million visitors from around the world, the Museum's campus is home to the world's most comprehensive collection of glass, the world's foremost library on glass, and one of the top glassworking schools in the world.

The campus of The Corning Museum of Glass is a unique collection of modern glass architecture. The Museum's buildings have been influenced by three distinct generations of architects, all of whom shared the goal of creating a fluid space and incorporating glass wherever possible.



Glass Production

Glassmakers take glowing gobs of molten glass on the end of a pipe and skillfully shape them into vases, bowls, or sculptures.

The glassblowing technique was discovered by the Romans around 50 B.C. and many of the techniques and tools used by glassmakers today have been used for thousands of years.

The demonstrators of the Hot Glass Team are some of the best glassmakers around.

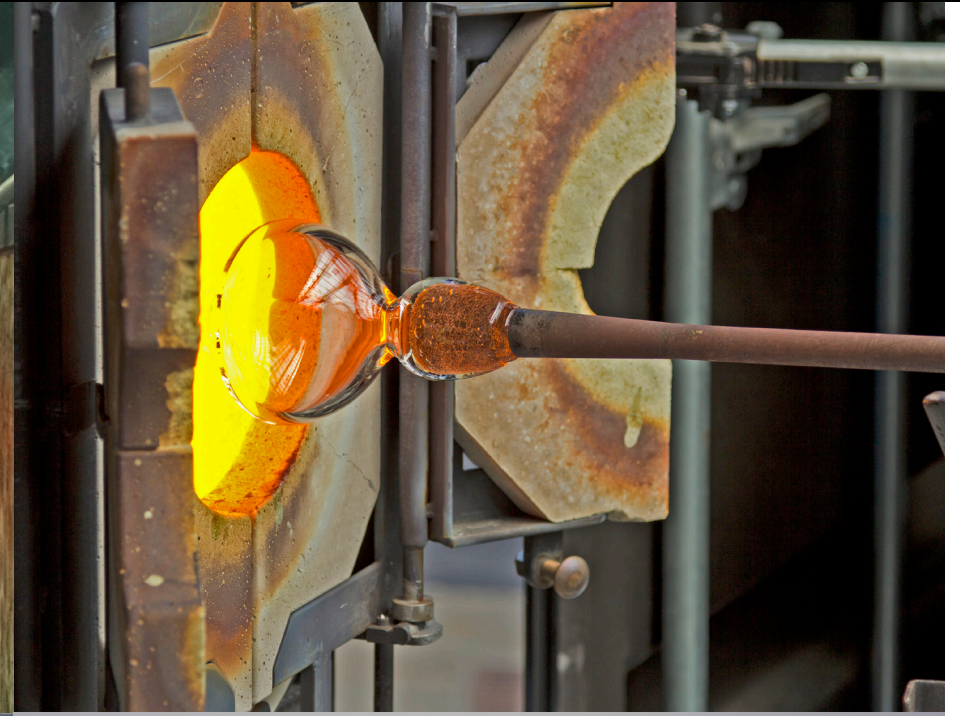

Collections

The world's most comprehensive and celebrated collection of glass, from Ancient Egypt to present-day contemporary glass art. Beautiful and captivating changing exhibits year-round.



Rakow Research Library

The Juliette K. and Leonard S. Rakow Research Library of The Corning Museum of Glass is the world's foremost library on the art and history of glass and glassmaking.

The Rakow Library's special collections and archives encompass materials ranging from medieval manuscripts about glass to contemporary glass artists' papers. Special collections and archives include rare books, manuscript collections, design drawings, batch books (glass recipe books), photographs, and ephemera, as well as historic records of The Corning Museum of Glass.

Currently, the Library has over 210 manuscript collections documenting glass collecting, the production and industrial design of American glass decorative art objects, individual glass artists' careers, archaeological excavations, and glass-focused organizations.

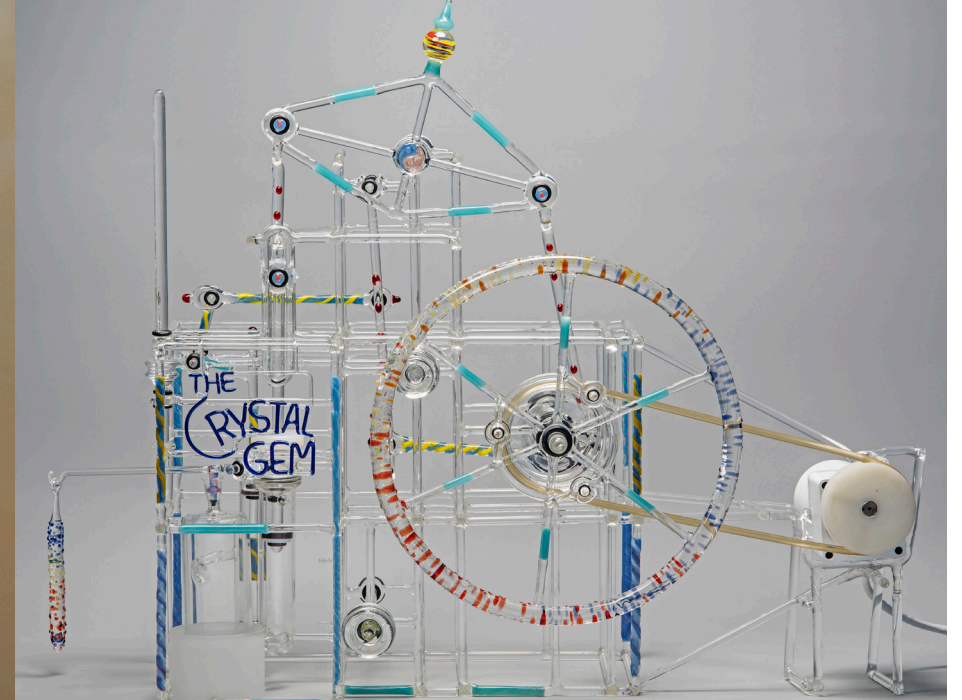

RIT + CMOG

Metaproject 02

2011

Under the guidance of Professor Josh Owen, RIT industrial design students worked with RIT glass program students to explore design concepts that capitalized on glass as the primary material through the Industrial Design course series known as Metaproject.

Josh Owen + CMOG GlassLab

2012

The Corning Museum of Glass invited Josh Owen to participate in their annual GlassLab workshop which gives select designers the opportunity to collaborate with glassmakers to rapidly prototype design concepts using the immediacy of hot glass as a catalyst for innovation.

Glass Lab Design Fellowship: Josh Owen + Selected Students

2012–2019

This fellowship provides one RIT Industrial Design student (either a graduating Senior or a graduating Graduate Student) the opportunity to participate in a two-day GlassLab session at the Corning Museum of Glass at end of May each year. This activity provides the student with an opportunity to explore glass as a medium for rapid prototyping of ideas and reinforces connections between design-education and the future of the glass medium between RIT and CMOG. Over the years eight students have been awarded this fellowship.

RIT Industrial Design + CMOG GlassLab Fellowship

2013

The GlassLab Design Fellowship provided one graduating RIT Industrial Design Graduate student with an opportunity to explore glass as a medium to rapid prototype ideas and participate in a two-day GlassLab session at The Corning Museum of Glass.

Activating the Archives: RIT Industrial Design + CMOG GlassLab

2014

Students partnered with The Corning Museum of Glass to design and develop a drinking vessel suitable for glass production with glass as the core medium of exploration. Students presented their ideas to CMOG leadership who then selected 3 exemplary student works to prototype in Corning.

Josh Owen + CMOG GlassLab + Boisbucet

2015

Josh Owen and The Corning Museum of Glass' mobile Glasslab were invited to lead an exclusive workshop developed to provide a unique opportunity for exploring the endless creative possibilities that glass-making offers.

GlassBarge in Pittsford: Josh Owen + Chuck Cerankosky

2018

In celebration of the 150th anniversary of glassmaking coming to Corning, NY by way of the Erie Canal, CMOG launched GlassBarge—a 30' x 80' canal barge equipped with CMOG's patented all-electric glassmaking equipment—in Brooklyn Bridge Park.

Vignelli Summer Design Workshop

2022

For the first Summer Design Workshop under Josh Owen's directorship of the Vignelli Center for Design Studies at RIT, a new partnership is forged. Seven international designers are selected to find inspiration in the Vignelli Archives, follow a creative brief and work with master glass makers at Corning to produce final designs.

Vignelli Summer Design Workshop

2023

For the second Summer Design Workshop under Josh Owen's directorship of the Vignelli Center for Design Studies at RIT, the project is enhanced. Nine international designers are selected to find inspiration in the Vignelli Archives, follow a creative brief and work with master glass makers at Corning to produce final designs.

Vignelli Summer Design Workshop

2024

After the success of the first two Summer Design Workshops under Josh Owen's directorship of the Vignelli Center for Design Studies at RIT, the project is expanded. Up to ten international designers are selected to find inspiration in the Vignelli Archives, follow a creative brief and work with master glass makers at Corning to produce final designs.

Workshop Leader

Josh Owen

Vignelli Distinguished Professor
Rochester, New York



Josh Owen is the Vignelli Distinguished Professor of Design and the Director of the Vignelli Center for Design Studies at RIT. Prior to his current role, Owen was Director of the Industrial Design Department in which he continues to teach his popular course known as the Metaproject.

Owen is also the president of his eponymous design studio, Josh Owen LLC. His professional projects are produced by major manufacturers and have won many awards. Owen's work is included in the permanent design collections of the Centre Georges Pompidou (FR), the Chicago Athenaeum (USA), the Corning Museum of Glass (USA), the Denver Art Museum (USA), the Design Museum Brussels (BE), the Museum of American Jewish History (USA), the Musee des beaux-arts de Montreal (CA), the Philadelphia Museum of Art (USA) and the Taiwan Design Museum (TP).

Owen's professional work has been featured in major exhibitions, numerous books on design and is regularly included in critical design discourse. He is the author of the book, *Lenses for Design* and the forthcoming book, *Design for Study*.



The evolution of a chair design is a process of...
The evolution of a chair design is a process of...
The evolution of a chair design is a process of...

Lenses for Design Josh Owen



There is a different general parameter...
There is a different general parameter...
There is a different general parameter...

Design Process Josh Owen



Lenses for Design Josh Owen



In the quietest domestic kitchen products...
In the quietest domestic kitchen products...
In the quietest domestic kitchen products...

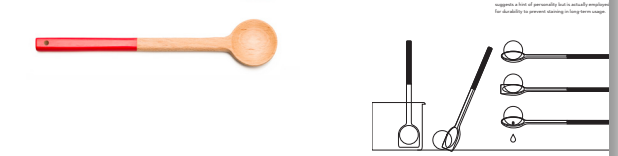

Lenses for Design Josh Owen



I found that some of these actions could be...
I found that some of these actions could be...
I found that some of these actions could be...

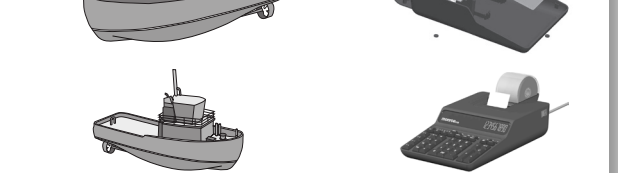

Lenses for Design Josh Owen

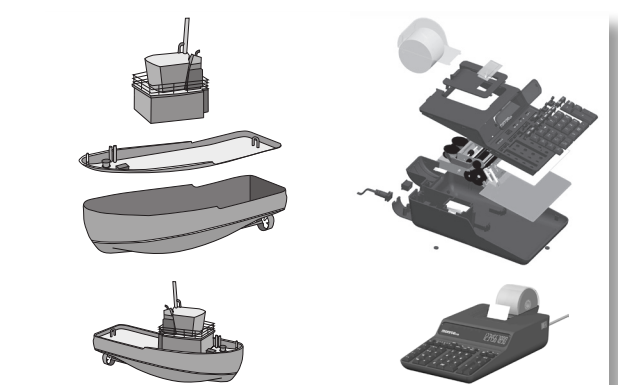

Design Process Josh Owen

Workshop Partner

Jennifer Whitlock

Vignelli Archives Archivist
Rochester, New York



Since 2013, Jennifer Whitlock has been the first and only archivist for the Vignelli Center for Design Studies at Rochester Institute of Technology (RIT).

Before arriving at RIT, Jennifer initiated an archives program for the Indianapolis Museum of Art, served as a project archivist and interim acting curator at the Architecture & Design Collection at University of California Santa Barbara, and also worked as an Assistant Librarian at the Portland Art Museum.

She holds a Master of Library Science with an Archives Certificate from Emporia State University and a BA in Photography from Webster University. She is also a Certified Archivist through the Academy of Certified Archivists and (formerly) a Digital Archives Specialist through the Society of American Archivists. She has worked at the Museum of American Jewish History (USA), the Musée des beaux-arts de Montréal (CA), the Philadelphia Museum of Art (USA) and the Taiwan Design Museum (TP).



Workshop Partner

Eric Meek

Senior Manager of Hot Glass Programs
Corning, New York



Senior Manager of Hot Glass Programs, Eric Meek has been a full-time gaffer at the Museum since 2005. After graduating from Bowling Green State University, Meek studied glassblowing at The Studio of The Corning Museum of Glass and the production studio at the Henry Ford Museum. He received his M.F.A. from Kent State University and teaches workshops internationally. His artwork is exhibited throughout the United States and Europe. When working with glass, Meek likes to draw upon tradition and fine craftsmanship to realize modern, elegant forms.

Eric Meek has worked to become a versatile glass artist, able to execute ideas in glass with fluency in the material. When working, Meek likes to draw upon tradition and fine craftsmanship to realize modern, elegant forms.

As a process-oriented artist, his personal style has often taken a back seat to his desire to become an accomplished technician. “I’ve been inspired by passionate makers I have met and their relationship to the material,” said Meek. “Their passion comes through the technique to give their work a special quality.”

After earning a degree from Bowling Green State University, Meek worked at the production studio at the Henry Ford Museum. He went on to earn his MFA from Kent State University and taught at the Glasfachschule Kramsach in Austria for six years. Meek first came to Corning, N.Y., to take classes, before starting as demonstrator and then teaching classes in glassblowing himself. A gaffer at the Museum since 2002, he has traveled extensively with the Museum through numerous outreach engagements and now manages the Museum’s hot glass programs.



Workshop Schedule

At the Vignelli Center

Sunday, June 2

Vignelli Archives session
Introduction by Josh Owen
Introduction to the Archives by Jennifer Whitlock
Tour the Vignelli Center
View *Design is One* film
Welcome Dinner

Monday, June 3

Participants deliver their design brief
Participants research project goals
Hot glass demonstration at RIT by
David Schnuckel

Tuesday, June 4

Project Design and Development
at the Vignelli Center
3D printing of project prototype
at Fab Lab

At The Corning Museum of Glass

Wednesday, June 5

Tour of Museum and Archives
Hear from Eric Meek and CMOG
stakeholders
Meet with glass craftspeople to learn
production methods

Thursday, June 6

Fabricate final glass project

Friday, June 7

Fabricate final glass project
Project critique by guest panellists
Farewell Dinner

Saturday, June 8

Documentation and departure

Studying Archival Materials
in the Helen Hamlyn Trust Study Room
left



Studying Archival Materials
in the Vignelli Archives
right



3D Printing at the Fab Lab
in RIT's College of Art and Design
left

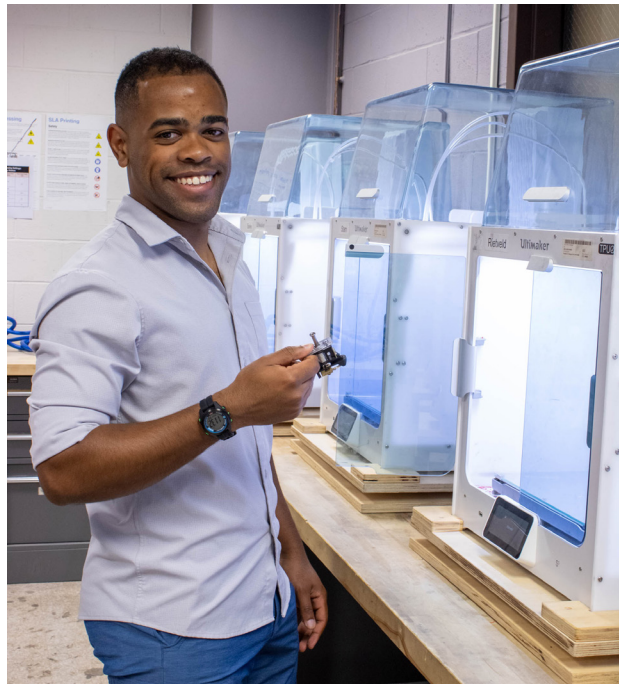

Project Work Session
in the Helen Hamlyn Trust Study Room
right







2022 Workshop Participants

Josh Owen, Jonathan Wajskol, Veronica Lin, Julie Hirschfeld, Jasper Owen, Reza Aliabadi, Jason Alger, Terri Lee

CORNING MUSEUM OF GLASS



2023 Workshop Participants

John Bechtold, Reza Aliabadi, Josh Owen, Maria Canale, Mark Havens, Lori Resch, Melissa Dawson, Paul McGroary, Peter Rossetti, Matt Silverman

